

---

# User manual

---

## Mobile DC Fast Charger



## Translation of original document

### Legal notice

Issued by	Designwerk Technologies AG Wülflingerstrasse 147 CH-8408 Winterthur info@designwerk.com +41 44 515 48 58 www.designwerk.com
	Member of the Volvo Group
Copyright	© Designwerk Technologies AG, 2025 The contents of this document may not be disclosed to third parties in whole or in parts without the written approval of Designwerk Technologies AG. All technical specifications, drawings and pictures used are copyright protected, and any infringement is punishable by law
Updates	Due to technical improvements to our products we reserve the right to make design changes. Any changes will be indicated in the individual manuals by replacing the respective pages or revision of the electronic data medium.

	<b>NOTICE</b>
	<p><b>Read and keep this document!</b></p> <p>Read this document carefully and follow the information contained in it. Failure to follow this instruction may result in injury, death, damage to the unit and the surrounding area. Keep this document for future reference.</p>

**Validity**

This manual only applies to the units listed in the following table:

Type	Model	Version
MDC	22-920	4.0

**Table of contents**

1	Foreword .....	6
2	Safety notices and warnings .....	7
2.1	Symbols and their meanings.....	7
2.1.1	Hazard and warning symbols .....	7
2.1.2	Commandment and information symbols.....	7
2.2	Safety notices and risk levels .....	8
2.3	General safety notices.....	9
2.3.1	Mechanical system safety notices .....	9
2.3.2	Electrical system safety notices .....	10
2.3.3	Safety notices for handling and operation.....	11
2.4	Safety units / power limitations .....	12
2.4.1	Coded CEE cables .....	12
2.4.2	Overload protection (derating) .....	12
2.4.3	Active discharge .....	12
2.5	User requirements .....	13
2.6	Network requirements .....	13
2.7	Disposal .....	13
3	General.....	14
3.1	Contents and scope of this manual .....	14
3.2	Scope of the complete documentation .....	14
3.3	Scope of delivery .....	14
3.4	Optional scope of delivery .....	14
3.5	Manufacturer contact information .....	16
3.6	Applied standards .....	16
4	Product use and limits .....	17
4.1	Intended use.....	17
4.2	Improper use / product limits .....	17
5	About this unit.....	18
5.1	Technical data .....	18
5.2	Basic functions.....	19
5.3	Transport and storage information .....	19
5.4	Operating position.....	20
6	Inspection MDC22 .....	21
6.1	Maintenance MDC22.....	21

6.2	Cleaning MDC	22
6.3	Spare parts	22
6.4	Product description MDC22	23
6.5	Type plate MDC22	24
7	Use and operation MDC22	25
7.1	Initial state MDC22	25
7.2	Preparing the charger MDC22	25
7.3	Charging the vehicle MDC22	26
7.4	Menu structure	27
7.4.1	Home screen	27
7.4.2	Info screen	27
7.4.3	Temperatures screen	28
7.4.4	AC information screen	28
7.4.5	Error message screen	29
7.4.6	Error log screen	29
7.4.7	Options screen	30
7.4.8	Current limits screen	31
7.4.9	Operating screen	32
7.4.10	Device info screen	33
7.5	Stopping charging	34
7.6	Storing the charger after use	34
8	Warranty	35
8.1	Warranty claims	35
8.2	Exclusion of warranty	35
9	Notes	36
10	Appendix	37
10.1	Errors and warnings	37

## **1 Foreword**

Dear Customer,

The MDC22 mobile DC fast charger is a very powerful and versatile product.

Please read this manual carefully – particularly the chapter “Safety Notices and Warnings” – before using or working on the charger.







## 2 Safety notices and warnings

This chapter contains safety notices for this unit. These pertain to initial use and ongoing use in the vehicle. Please read and always observe these notices for safety reasons and to prevent loss of life and unit damage.



### 2.1 Symbols and their meanings

This manual uses various symbols. The following chart contains a list and their meanings:





#### 2.1.1 Hazard and warning symbols

	Do not touch. Housing is under voltage.		General warning of a danger zone
	Warns of high voltage		Warns of fire hazard
	Warns of hot surfaces		Warns of explosion hazard

#### 2.1.2 Commandment and information symbols



Symbol	Designation	Symbol	Designation
	Important information to avoid potential property damage		Important information

**2.2 Safety notices and risk levels**

	<p><b>DANGER</b></p> <p><b>Danger</b></p> <p>To indicate an imminently hazardous situation which, if not avoided, will result in death or serious injury</p>
	<p><b>WARNING</b></p> <p><b>Warning</b></p> <p>To indicate a potentially hazardous situation which, if not avoided, could result in death or serious injury.</p>
	<p><b>CAUTION</b></p> <p><b>Caution</b></p> <p>To indicate a potentially hazardous situation which, if not avoided, could result in a minor or moderate injury.</p>
	<p><b>NOTICE</b></p> <p><b>Notice</b></p> <p>To indicate important information to avoid possible damage to property.</p>
	<p><b>INFORMATION</b></p> <p><b>Information</b></p> <p>To indicate important information for the reader.</p>

**2.3 General safety notices**

**2.3.1 Mechanical system safety notices**

	<p><b>DANGER</b></p> <p><b>Explosive environment</b> <b>Life threatening</b></p> <p>Do not store highly flammable substances or flammable liquids in the direct vicinity of the unit! Sparks at the unit connections may ignite these and result in explosions.</p>
	<p><b>CAUTION</b></p> <p><b>Hot plug</b> <b>Risk of burns</b></p> <p>The connection of the DC charging cable is designed for at least 500 charging cycles. If this number is exceeded, or in exceptional cases even before, the plug may heat up considerably. In these cases, the warning sticker will change color. In such cases, stop using the charger and contact Designwerk immediately.</p>
	<p><b>CAUTION</b></p> <p><b>Hot surfaces and hot exhaust air</b> <b>Danger of burns</b></p> <p>The unit produces high temperatures during operation! Therefore, always be careful and cautious when handling the unit!</p> <p>The connection of the DC charging cable can become very hot during operation.</p>

**2.3.2 Electrical system safety notices**





	<b>DANGER</b>
	<p><b>Mains voltage or high voltage</b></p> <p><b>Danger to life</b></p> <p>Connect the unit to a connection that complies with the electrical regulations. The local regulations must be observed. Our charger has a built-in current sensor which, in the event of a fault current <math>\geq 6 \text{ mA DC}</math> (with the MDC22) leads to a charging termination.</p>

	<b>CAUTION</b>
	<p><b>Overheating of the cables</b></p> <p><b>Fire hazard</b></p> <p>If a cable roll is used as an extension to the mains connection, it can ignite due to heat build-up! Therefore, always unwind cable rolls completely!</p>

	<b>CAUTION</b>
	<p><b>Earth connection is mandatory</b></p> <p>The charger may only be used on sockets with an earth connection.</p>

	<b>NOTICE</b>
	<p><b>Do not open device without authorization</b></p> <p>Never open the unit unauthorised. Opening the unit (sealed housing) will immediately void any warranty and guarantee claims against Designwerk Technologies AG.</p> <p>The unit contains capacitors that still have residual voltage even when unplugged.</p>

### 2.3.3 Safety notices for handling and operation

	<p><b>NOTICE</b></p>
	<p><b>HV battery damage</b></p>
	<p>Only use the charger on electric vehicles in good technical conditions. Do not use the unit, if the vehicle reports errors before connecting it to the charger.</p>
	<p><b>NOTICE</b></p>
	<p><b>Damage to cable connections</b></p>
	<p>Check the AC and DC cable for defects before every use. Verify the cables are properly plugged in and locked.</p>
	<p><b>NOTICE</b></p>
	<p><b>Only use the DC cables supplied</b></p>
	<p>Please only use the DC cables included in the scope of delivery or DC cables provided by Designwerk. The use of DC to DC conversion kits is not permitted. DC extensions are also not permitted.</p>
	<p><b>NOTICE</b></p>
	<p><b>IP protection class and environment</b></p>
	<p>The environment of the charger must correspond to its IP protection class.</p>

## 2.4 Safety units / power limitations

### 2.4.1 Coded CEE cables

When using the power cables supplied, the unit automatically detects the cable and limits the current to the maximum permissible current.

	<b>NOTICE</b>
	<p><b>Use the cover cap of the charger plug</b></p> <p>If the charging cable is not plugged into the charger, it must be closed with the cap supplied.</p>

	<b>NOTICE</b>
	<p><b>Use only supplied AC cables</b></p> <p>Please only use the AC cables included in the scope of delivery or AC cables provided by Designwerk. Connecting standard CEE Extension cables after the included AC cables is permissible.</p>

### 2.4.2 Overload protection (derating)

This unit is designed to work without reduced charging power (derating) up to an outside air temperature of 40°C. In the event of outside air temperatures over 40°C, the unit automatically reduces the charging power to protect the charger from damage due to overheating. Power is reduced proportional to the temperature rise.

### 2.4.3 Active discharge

The unit has an active discharge of the external connections, which is activated if charging is interrupted, or the unit is disconnected from the mains.

## 2.5 User requirements

The charger may only be operated by persons who have received detailed instructions for the device and/or have read and understood this manual in full.

The charger may only be connected to a TN or TT mains supply.

## 2.6 Network requirements

Use industrial or country-specific sockets.

Before connecting the device to the mains, ensure the following:

- The cables and plugs used are undamaged.
- The mains installation is adequately protected (LS) and there is a residual current device (FI).
- The residual current device (RCD) was evaluated depending on the country and location.
- The connection cables have been fully unrolled to prevent heat build-up.
- The plugs are correctly and fully inserted.
- No plugging procedures are carried out under load.



## Manual reduction of the unit current

All power cables supplied have a coding that limits the maximum current. If connections (e.g., worksite distribution boards) are unable to safely handle the rated current for any reason, the maximum current can also be manually limited in the menu.

## 2.7 Disposal

This unit is marked in accordance with directive 2012/19/EU on Waste Electrical and Electronic Equipment – WEEE. The directive provides the framework for the EU-wide take-back and recycling of waste equipment.

This charger is made of recyclable materials. Local regulations may require separate disposal of electrical and electronic products, including cables, plugs and accessories.

 	<b>INFORMATION</b>
	Never dispose of old units with household waste. The unit must be returned to Designwerk Technologies AG or an electrical retailer to ensure proper disposal. <b>WEEE Registration Nr. DE 42721147</b>

### 3 General

#### 3.1 Contents and scope of this manual

This documentation provides the reader with an overview of all steps required to install and operate the charger and the necessary safety mechanisms.

It further contains technical data, application information and a basic description of the charger and its functions.

The operating information and safety notices must be followed exactly to ensure proper charger function long-term and to observe the warranty requirements of Designwerk Technologies AG.

#### 3.2 Scope of the complete documentation





The manual contains the following documents:

- Technical documentation
- Use and operation
- Warranty terms

#### 3.3 Scope of delivery

Designation	Article No.	Illustration
Fast charger MDC22-920	305022	

#### 3.4 Optional scope of delivery

	Designation	Article No.	Illustration
1	DC cable I CCS Typ2 4 m	300207	
2	DC cable CCS Typ2 8 m	305075	
3	DC cable CCS Typ1 4 m	300208	
4	DC cable GB/T 4 m	300210	

	Designation	Article No.	Illustration
5	DC cable CHAdeMO 4 m	300209	
6	DC cable NACS 4 m	116535	
7	AC cable CEE 16 A 5 m	300213	
8	AC cable CEE 32 A 5 m	300212	
9	Trolley	305016	
10	Wall mount	305024	
11	Flightcase	305033	

### **3.5 Manufacturer contact information**

Designwerk Technologies AG  
Wülflingerstrasse 147  
CH-8408 Winterthur  
Ph +41 44 515 48 58  
info@designwerk.com

### **3.6 Applied standards**

For the applied standards, see the Declaration of conformity.

The document can be accessed via the Designwerk service portal at:  
<https://serviceportal.designwerk.com>.

This manual is prepared under application and observance of the EC directives, national laws and harmonised standards (EN) concerning the fast charger product and valid at the time.

## 4 Product use and limits

### 4.1 Intended use

The DC fast charger is designed for charging of electric and hybrid vehicles and drive units with DC fast charge connector and is intended for distribution and use in the EU and EFTA market. Export or use outside the EU and EFTA may be unauthorised. Should it be intended for any other purposes, please contact Designwerk Technologies AG with any questions.

The following limits are defined for operating the fast charger. Operation outside these specified limits may result in damage to the unit and subsequently life-threatening situations and is therefore prohibited!

Limit type	Compliance Values	Unit
3-phase input voltage	400 ± 10 %	VAC (ph-ph)
Ambient temperature for storage	-20 to +70	°C
Ambient temperature for operation	-25 to +50	°C
Max. unit operating height	2000	above sea level

### 4.2 Improper use / product limits

Improper means any use in conditions and under requirements which do not observe with those specified by the manufacturer in the technical documentation and data sheets.

## 5 About this unit

### 5.1 Technical data

AC input	Value	Unit
	MDC22-920	
3-phase input voltage	400 ± 10 %	VAC (ph-ph)
Maximum 3-phase input voltage	32	A
Input frequency	50 ± 0,2	Hz
Max. input power	22	kW
Power factor	> 0.99	-
Power Factor Correction (PFC)	ja	-

DC output	Value	Unit
	MDC22-920	
Voltage range with reduced power	200-950	VDC
Voltage range at full power	150-1000	VDC
Maximum charging current	60	A
Minimum charging current	0	A
Continuous charging capacity	21	kW

#### U-I Diagramm MDC 22-920:

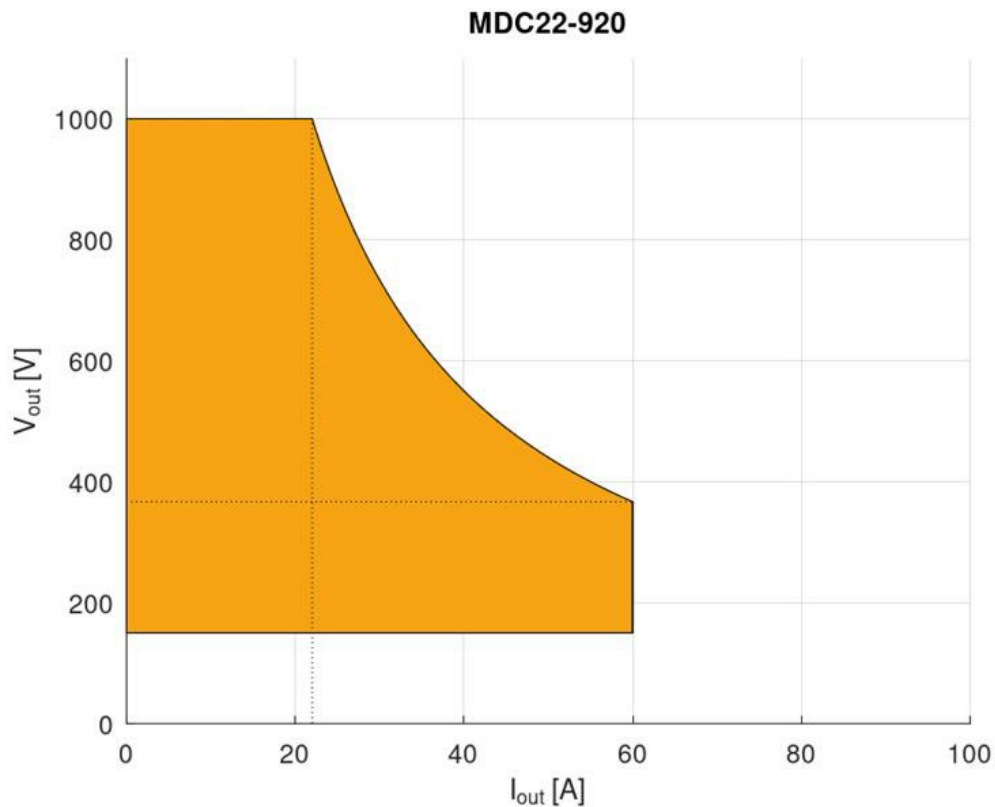

Thermal / cooling system	Value	Unit
	MDC22-920	
Ambient temperature for storage	-25 up to +70	°C
Ambient temperature for operation	-25 up to +50	°C

Basic mechanical data	Value	Unit
	MDC22-920	
Weight (without cables)	39	kg
Housing material	Aluminium	-
Housing volume	61.2	l
IP rating	54	-
IK rating (except for the display)	8	-
Height	510	mm
Width	240	mm
Length	500	mm

Safety and protection functions	Value	Unit
	MDC22-920	
Mains input excess voltage protection (ph-PE)	275	VAC
Mains input excess voltage protection (ph-PE)	460	VAC

## 5.2 Basic functions

The fast charger charges electric and hybrid vehicles with DC connection such as CCS Combo Type 2, GB/T, NACS and CHAdeMO.

## 5.3 Transport and storage information

The charger MDC22 is designed to be transported lying down (on its side) or upright.

The charger MDC22 is designed to be transported upright.

It is not recommended to transport the units upside-down or on the frontside on the cable connections. It is recommended to transport the MDC22 lying down. Always ensure the unit cannot shift during transport.

The optimum storage position is upright.

**5.4 Operating position**

If possible, the unit should be operated upright, with the display facing upwards. In principle, other operating situations are possible, but then a significant thermal derating must be expected.

	<b>NOTICE</b>
	<p><b>Optimal air circulation</b></p> <p>It is important that the air inlet and outlet are free from objects so that the cooling air circulates optimally.</p>

	<b>NOTICE</b>
	<p><b>Damage due to falling over</b></p> <p>Should the standing unit fall to the side, then hardware damage must be assumed. In this case, the unit should be returned to Designwerk Technologies for inspection. A proper fault-free function is no longer guaranteed.</p>

**6 Inspection MDC22**

The AC and DC cables and their connectors are subject to wear over time depending on the environment and handling. It is therefore important to check the condition of the cables and the plug contacts with every connection cycle.

Temperature-sensitive stickers may be attached to the plug connection between the charger and the cable. These turn black when a certain temperature is exceeded. If you discover a black sticker during an inspection, please contact the support.

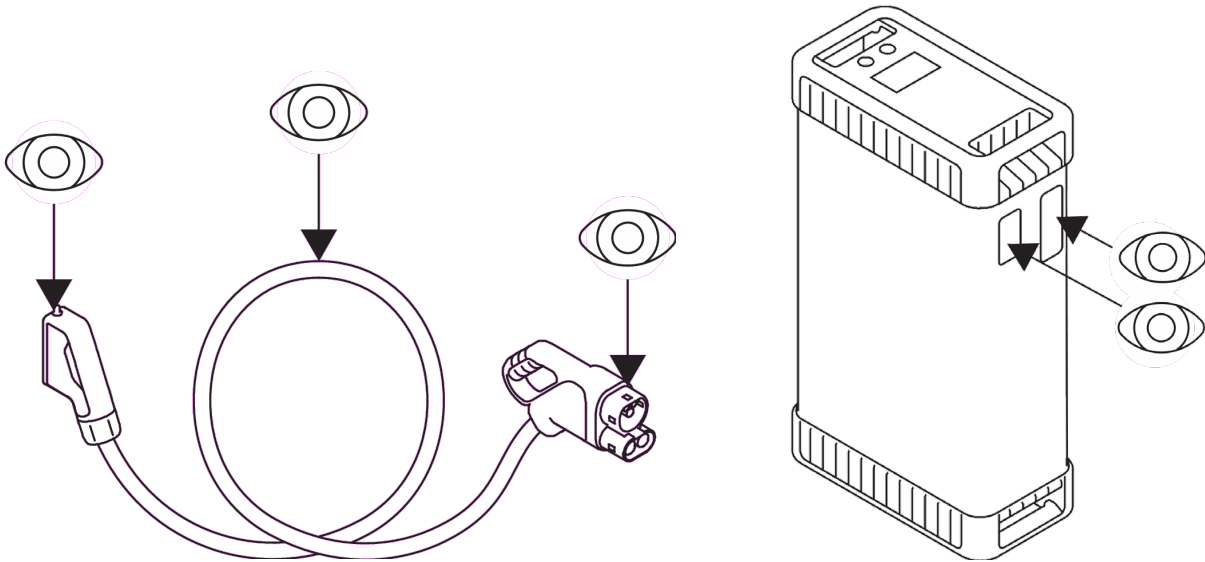

**6.1 Maintenance MDC22**

No regular maintenance is required due to the air cooling and particularly through the air inlet situated in the upper part of the unit.

Should however the unit be used in an extremely dusty environment, the cooling channel in the middle of the unit may become blocked over time. As a result, the fans run at higher speeds and the unit starts derating at lower temperatures.

In this case, the cooling duct can be vacuum cleaned with an industrial vacuum cleaner at the air inlet at the top and the air outlet at the bottom.

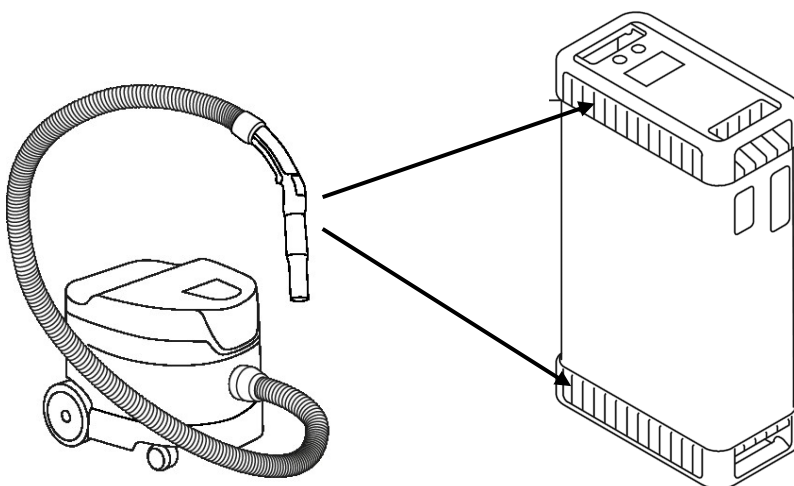

Should this procedure not eliminate the problem, then more extensive cleaning is necessary. Please contact our customer service.

**6.2 Cleaning MDC**

Use a damp cloth to clean the unit. Should performance be impaired due to contamination in the cooling channel of the unit, proceed as described in section 6.1.

	<b>NOTICE</b>
	<p><b>No cleaning with high pressure cleaner</b></p> <p>Never use a high-pressure cleaner to clean the unit as this might lead to damages.</p>

**6.3 Spare parts**

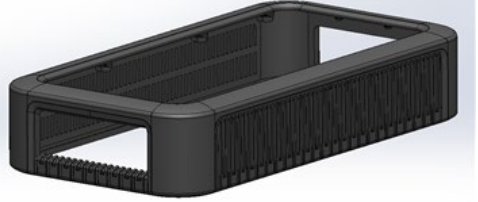
Designation	Article No.	Illustration
Rubber cover for charger	101159	
Castor wheel for trolley	502642	
Castor wheel with brake for trolley	502643	
Spare cable	see chapter 3.4	

Various other components of the charger are available as spare parts and are available for replacement independently in consultation with our customer service.

**6.4 Product description MDC22**

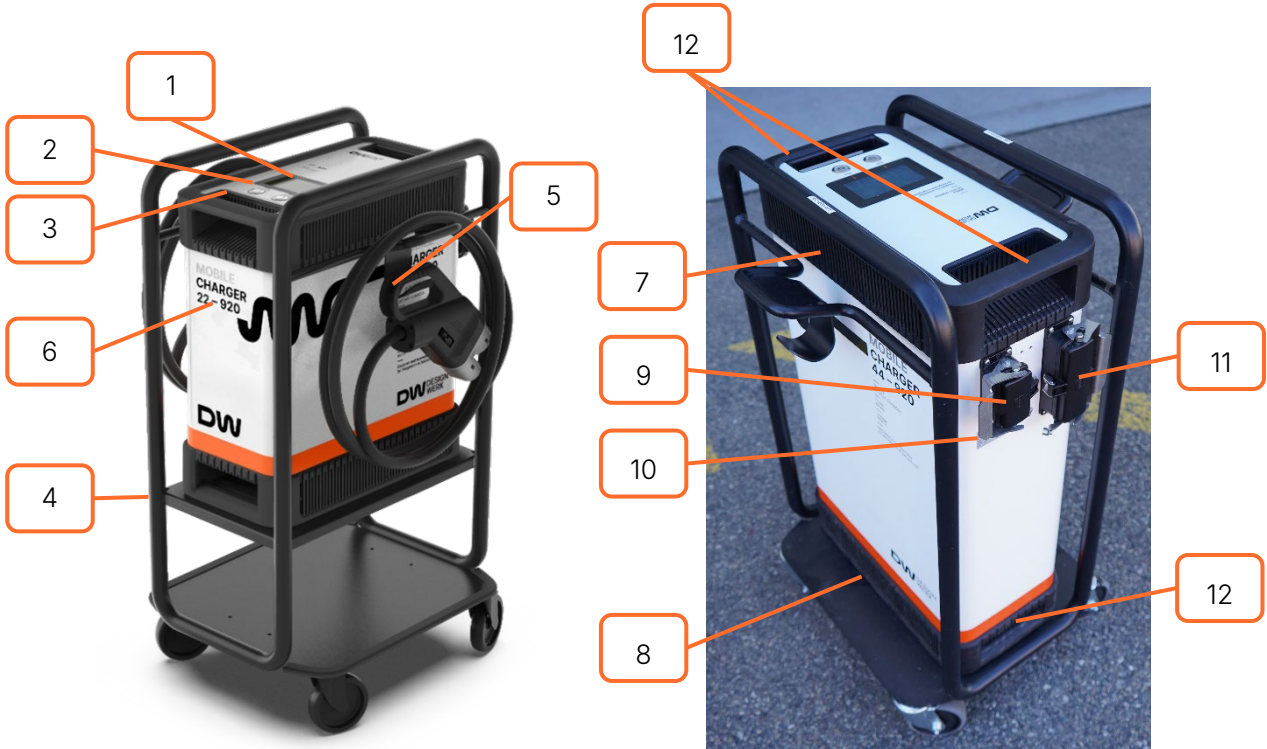

1	Display	7	Air intake
2	Control buttons	8	Air outlet
3	USB port	9	AC mains connections
4	Trolley	10	Type plate
5	Cable rewind wing	11	DC cable connection
6	Product identification	12	Carrying handles

**6.5 Type plate MDC22**

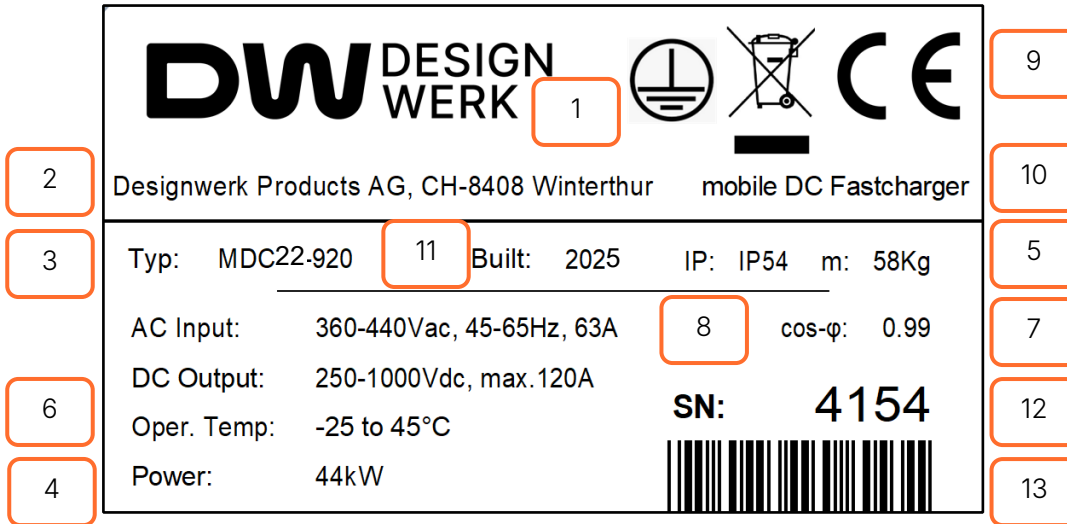

1	Company logo	8	IP rating
2	Company address	9	CE mark
3	Type designation	10	Voice unit designation
4	Input power range	11	Year of manufacture
5	Unit weight	12	Serial number
6	Permissible temperature range during operation	13	Barcode
7	Power factor correction (PFC)		

**7 Use and operation MDC22**

	<b>INFORMATION</b>
	The fast charger shown is higher than the one described.

**7.1 Initial state MDC22**

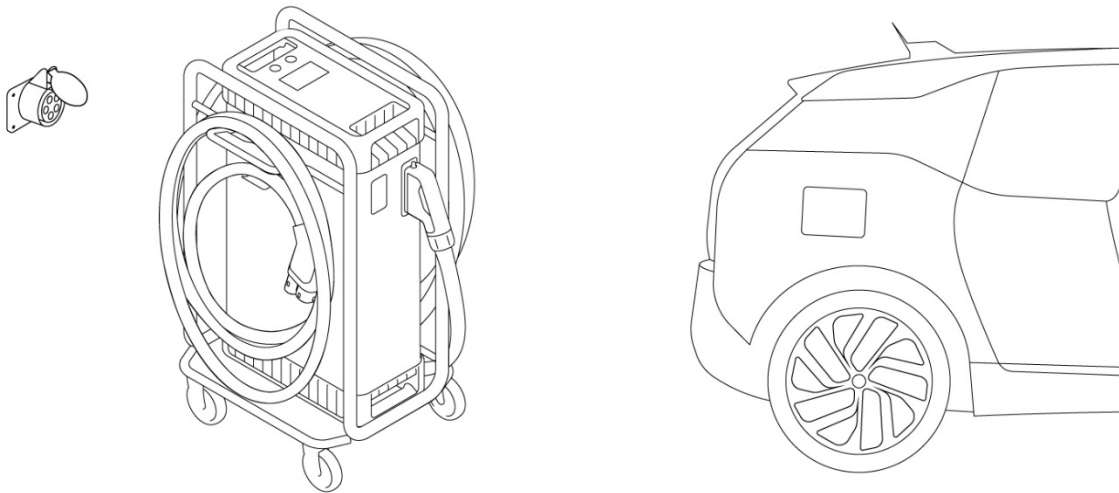

A CEE63 A/400 V or CEE32 A/400 V industrial socket is required for fast charging. Park your vehicle so that the fast charger reaches the mains connection with the supplied cables and the cables lie on the ground and are not under tension.

**7.2 Preparing the charger MDC22**

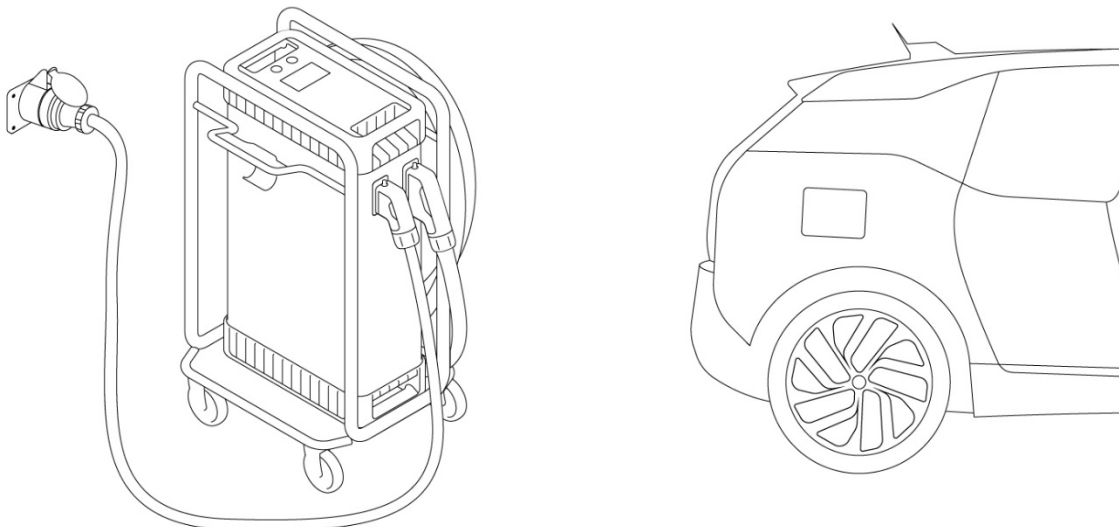

Plug the DC cable and the AC cable into the fast charger. Now connect the AC cable to the mains.

**7.3 Charging the vehicle MDC22**

The unit runs an initialisation depending on the protocol. As soon as the unit is ready for operation, the message 'Waiting for Vehicle' appears on the display. Now plug the DC plug into your vehicle. The fast charge starts automatically or press the start button on the fast charger, depending on the charging protocol. The menu structure provides you with a variety of information during the charging process.

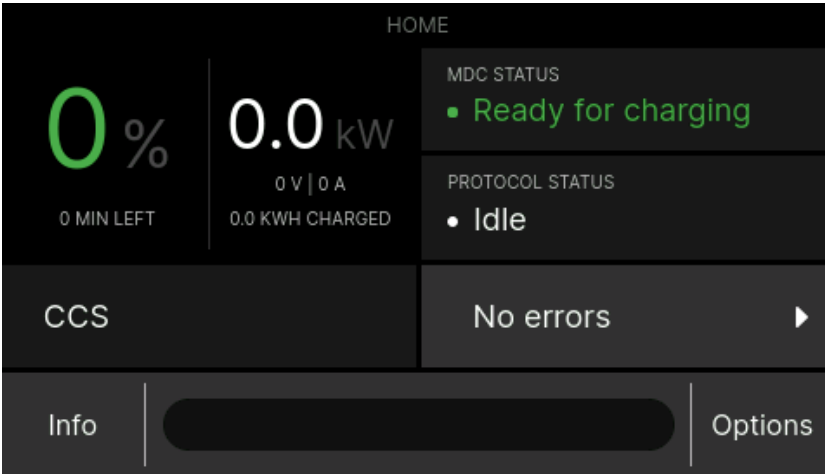

	<b>INFORMATION</b>
	<p>The Start button has no function when operating with CCS. The charging process starts automatically when the CCS plug is connected.</p>

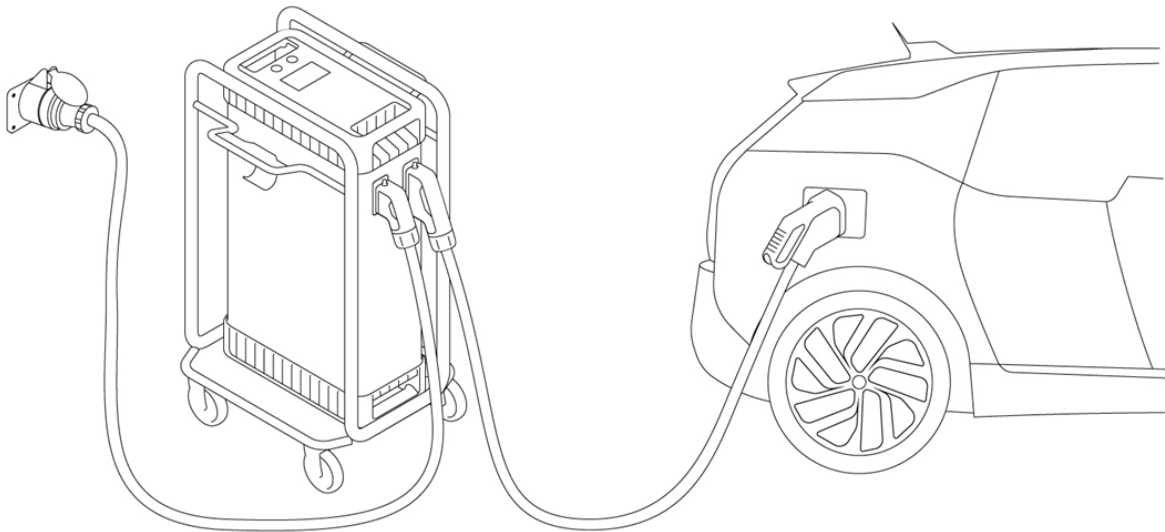

## 7.4 Menu structure

### 7.4.1 Home screen

This displays all the information necessary for the user during normal operation.

This screen allows access to the following:

- Options screen
- Info screen
- Error message screen

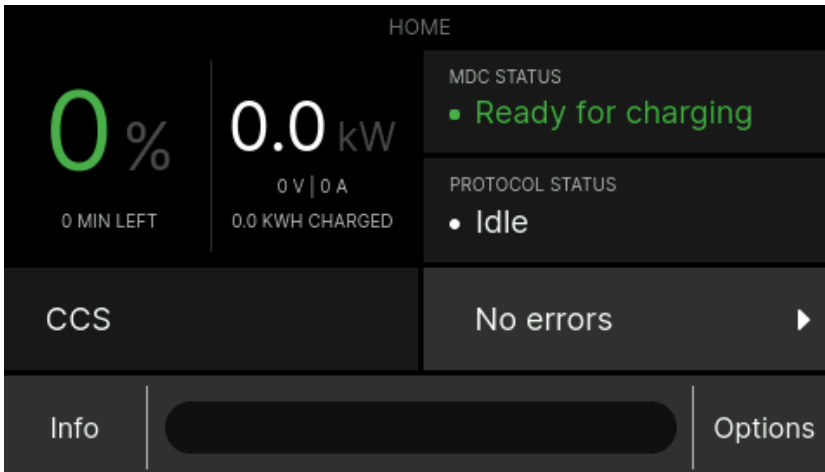

### 7.4.2 Info screen

This screen provides additional information on the current charging process.

This screen allows access to the following:

- Back to Home screen
- Device info screen
- Temperatures screen
- AC information screen
- Error message screen

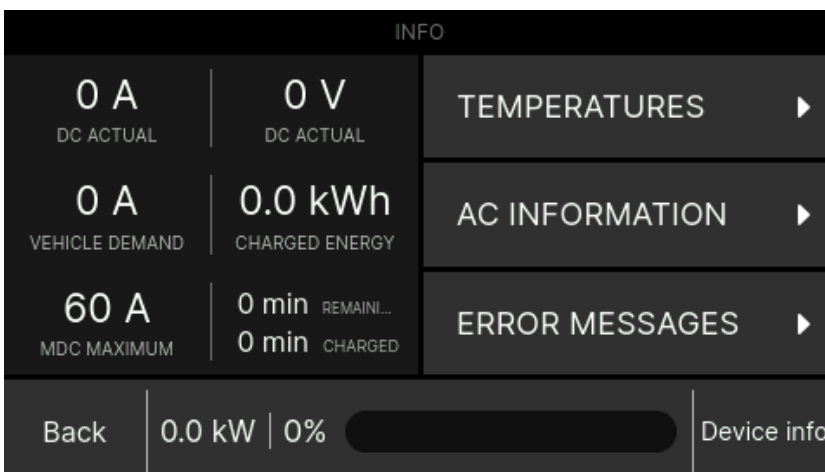

### 7.4.3 Temperatures screen

This displays the current temperatures for the respective measuring points.

This screen allows access to the following:

- Return to Info screen
- Options screen

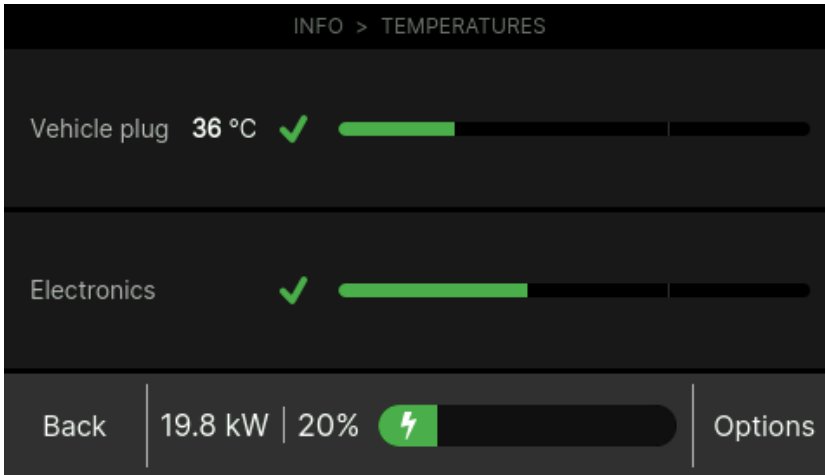

### 7.4.4 AC information screen

This screen displays information about the current status of the mains connection.

This screen allows access to the following:

- Return to Info screen
- Options screen

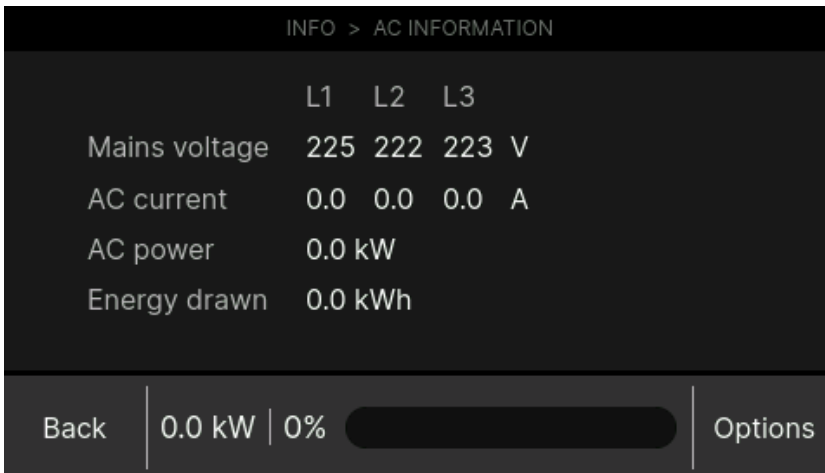

### 7.4.5 Error message screen

Any errors and warnings are displayed here.

This screen allows access to the following:

- Return to Info screen / Home screen
- Error log screen

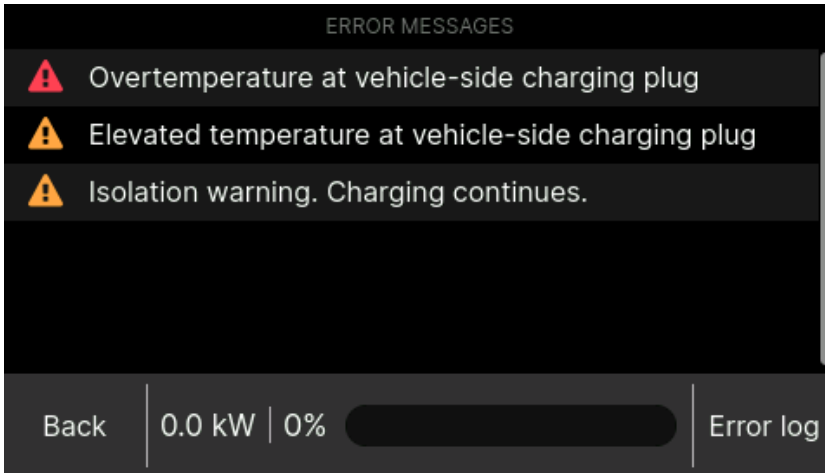

### 7.4.6 Error log screen

This lists current and past errors and warnings.

This screen allows access to the following:

- Back to Error Messages screen

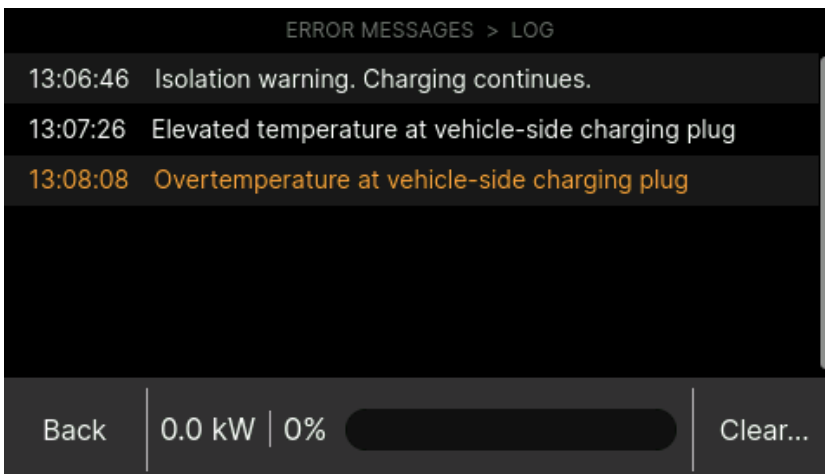

### 7.4.7 Options screen

This screen allows you to change settings and parameters.

This screen allows access to the following:

- Limits screen
- Clock screen
- Operating screen
- Device info screen
- Back to previous screen

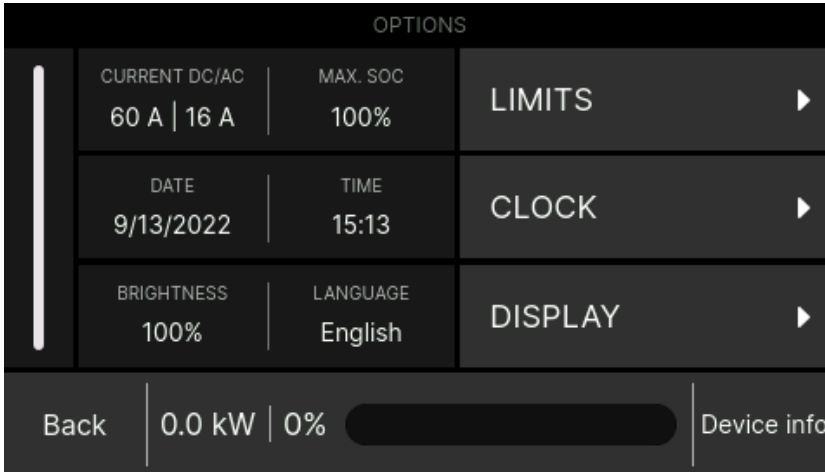

**7.4.8 Current limits screen**

The current limits on the input and output end are set here. The option limit is limited by the coded AC connection cable inserted on the mains side.

It is also possible to set up the SoC for the vehicle being charged.

This screen allows access to the following:

- Return to Options screen

The slider bar "AC Current Limit" considers the maximum current of the AC cable currently plugged in. If an AC cable is used that supports a smaller maximum current than the charger, the slider bar shows an arrow at the cable limit position and is thinner to the right of it. The adjustment knob can still be pushed past the cable limit with the current limit indicator remaining there. The charger remembers the visible position of the adjustment knob. When changing to a stronger AC cable, only this position determines the new current limit, the maximum current of the previous cable has no influence on it.

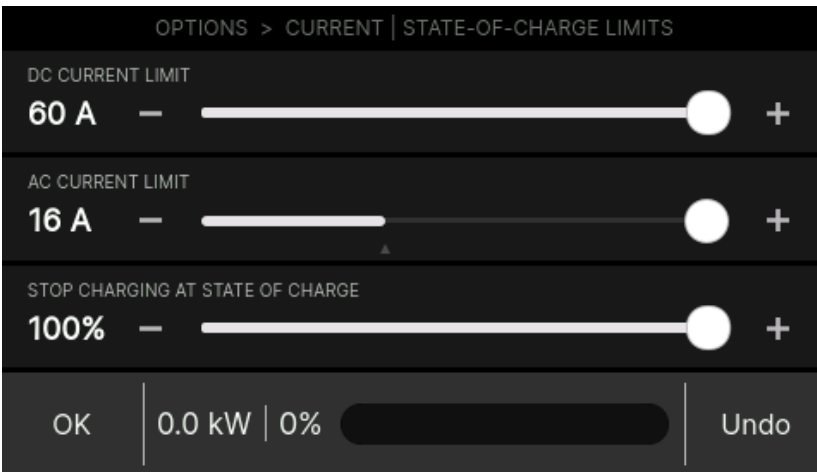

16 A cable, adjustment knob to 32 A, effective current limit 16 A.

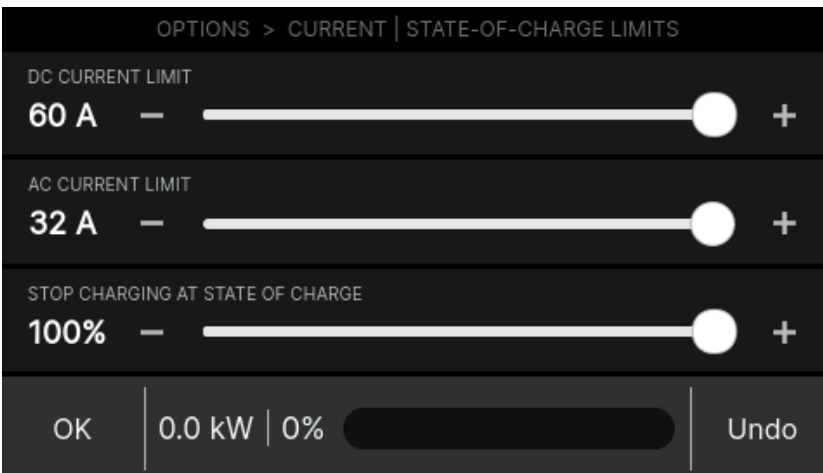

Change to 32 A cable (without new setting) results in effective current limit of 32 A.

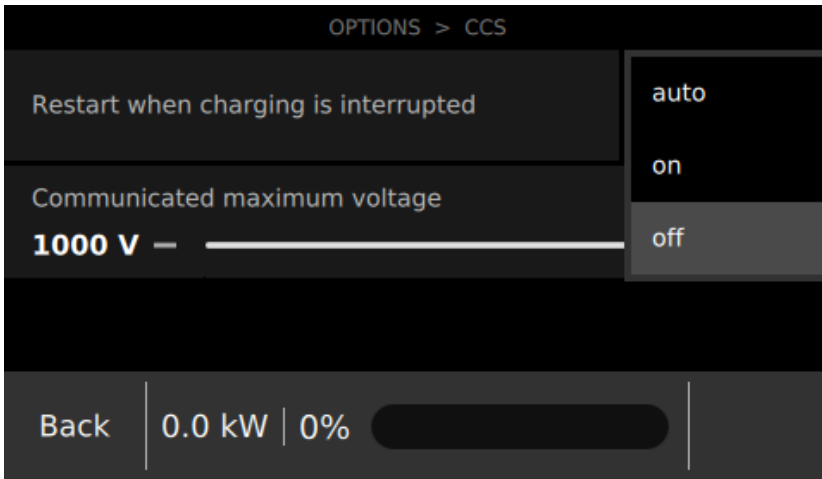

Optionally, the DC output voltage can be adjusted in the range from 300 V to 1000 V.

#### 7.4.9 Operating screen

This screen allows you to select the display brightness and the language.

This screen allows access to the following:

- Return to Options screen

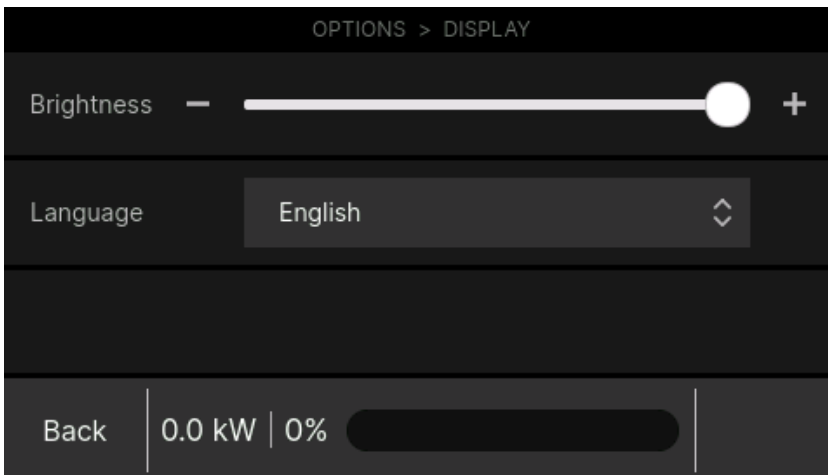

### 7.4.10 Device info screen

This screen displays the software versions and the operating data since being commissioned.

The internal logs can be stored on a USB stick.

This screen allows access to the following:

- Return to Options screen
- Versions screen

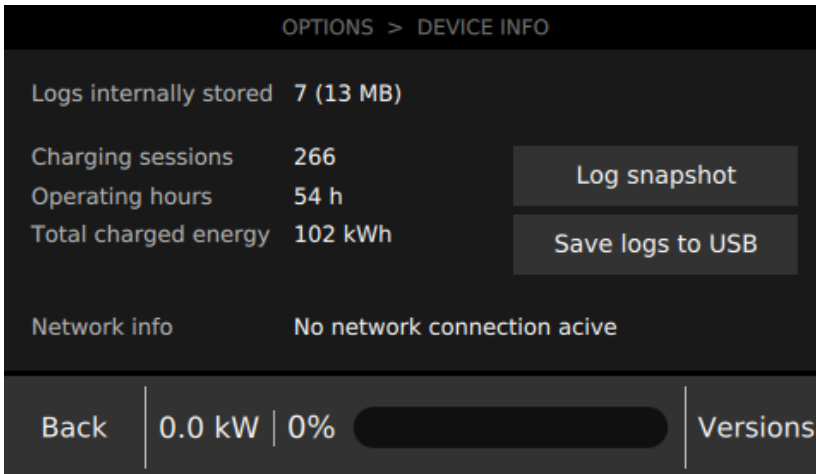

The installed version of the individual components can be displayed via the Versions window.

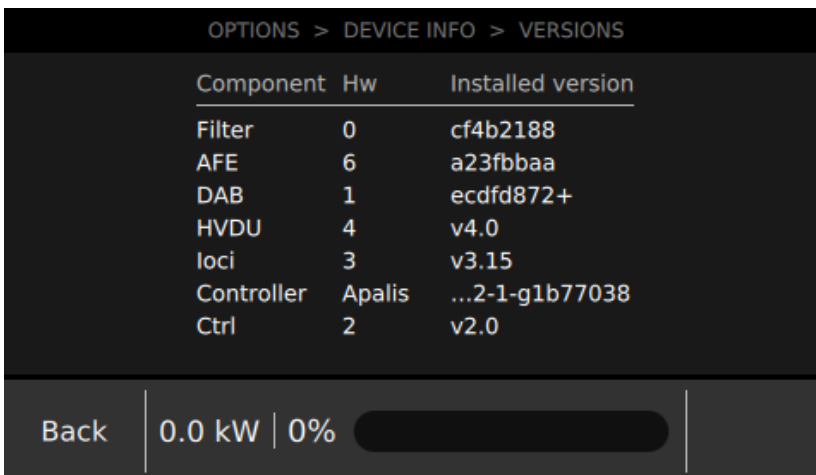

Technical changes to the menu structure are reserved.

## 7.5 Stopping charging

Charging automatically ends when the battery is full. Depending on the vehicle you will then merely need to disconnect the DC plug from the vehicle or first unlock the charging port in the vehicle or with the keyless remote.

When you want to stop charging before charging is complete, press the STOP button. Other vehicles may now be charged or store the unit away.

## 7.6 Storing the charger after use

The cooling system of the unit cooling may continue after charging stops at full power. However, the unit can still be unplugged and packed up. Please note though that the unit may be hot.

You should first finish. You can then unplug both ends of the AC cable. To store the unit away, you will now merely need to disconnect the DC cable from the unit.

	<p><b>NOTICE</b></p>
	<p><b>Close open plug connections</b></p> <p>If you unplug the AC or DC cable, you must close the open connectors with the cover. Otherwise, the IP protection cannot be guaranteed.</p>

When storing the unit away, please note the transport and storage information in chapter 5.4.

## **8 Warranty**

Designwerk Technologies AG offers a 24-month warranty from the date of purchase for obvious defects in function, material and manufacture. The warranty is valid within the European Union and the EFTA countries and is designed as a bring-in warranty.

### **8.1 Warranty claims**

- Please always contact us before sending in the product. We will then discuss further proceedings with you.
- If the defect is covered by our warranty, you will receive a repaired or new unit.

### **8.2 Exclusion of warranty**

The warranty is immediately void if the seal on the housing is damaged due to unauthorised opening or missing entirely. Designwerk Technologies AG further assumes no liability for damages due to handling or using the unit improperly or incorrectly.

Designwerk Technologies AG assumes no liability for personal injury due to failure to observe the general and/or product-specific safety notices.

Designwerk Technologies AG assumes no liability for damage to peripherals associated with this unit. Should you be unsure about using this product, please contact our support team PRIOR to use.

## **9 Notes**

We reserve the right to make changes in the interest of technical advancements. Designwerk Technologies AG cannot guarantee that all requirements, regulations and standards are free of third-party industrial property rights.

## 10 Appendix

### 10.1 Errors and warnings

Event		Description
Charging protocol error		An error has occurred in the communication with the vehicle. This may be caused by an incompatible or faulty implementation of the loading protocol on the vehicle side. Please contact our customer service in this case.
Unexpected charging interruption		CCS charging options: off: The charging process remains interrupted, the device does not restart the charging process. auto: the charger attempts to start the charging process using BCB toggle on: same as auto
Installation error	Phase L1 is not connected.	No voltage is detected on the respective phase. Please check the electrical installation. Damage may also be caused by excess voltage in certain circumstances.
	Phase L2 is not connected.	
	Phase L3 is not connected.	Please contact our customer service if voltage is present on all three phases and the fault persists.
	Mains voltage too low	The mains voltage is too low, please check the electrical installation
	Mains frequency not permissible	The mains frequency is outside the specified range, please check the electrical installation.
Internal error		There is an internal error. Please contact our customer service in this case.
Insulation error		An insulation error is detected on the DC side. Please check the charging cable and the vehicle.
Increased temperature at the vehicle's charging plug		The charging power is reduced because the temperature at the DC contacts of the vehicle charging plug is too high. Please check the contacts and replace the charging cable if necessary.
Excessive temperature at the vehicle's charging plug		The charge is interrupted as the temperature at the DC contacts of the vehicle charging plug is too high. Please check the contacts and replace the charging cable if necessary.